

# panel preparation guide

for elevator touchscreen systems



elevator  
touchscreen  
systems

# Chapter 1: System Overview

## Overview Component Identification Component Summary Supported Panel Types Component Placement Guidelines

---

### Overview

An elevator touchscreen system takes the place of conventional floor buttons inside an elevator.

In a typical installation, touchscreens are permanently mounted inside the elevator panels in the location where floor buttons are usually placed. The touchscreens show graphics representing the floors served by the elevator, and passengers enter floor requests by touching the appropriate area of the touchscreen. The touchscreen graphics change state to indicate that the request was recognized, and the elevator takes the passenger to the requested floor. Upon arrival at the floor, the graphics return to their original state.

An elevator touchscreen system provides many benefits over traditional buttons, including:

- The ability to fully customize the touchscreen graphics to match the style, identity, and branding of the property in which the system is installed.
- The ability to provide additional information to passengers, such as map data, floor contents, or tenant names and logos
- The use of large print and familiar icons to make the property more accessible
- The ability to change the appearance and contents of the screen on demand or on a scheduled basis

Successful deployment of an elevator touchscreen system involves three steps:

- Elevator panel preparation and fabrication
- Preinstallation of selected components at the point of panel fabrication (optional)
- Final installation and testing (on-site)

This document covers the first of these steps - elevator panel preparation. It will describe how to design an elevator panel that houses a touchscreen system, including component placement, cutout sizes, stud locations, and basic wiring requirements.

Whether you are manufacturing your own panel in-house or contracting the work to a fabrication facility, your Touch-To-Go project manager is available to assist you with the panel design process. Please contact us if you have any questions or concerns regarding component sizes, placement, or mounting. We are also available to review your final panel drawings prior to manufacturing.

# Component Identification

The following diagram shows a typical installation in an elevator with center-opening doors and dual swing-return car-operating panels.

➡ Many system configurations are possible (1 or 2 panels, 1 or 2 touchscreens, keypad or regular buttons, center or side opening doors, swing return or applied panels, etc.). The diagram shows just one of many possible configurations, and it is intended only for component identification purposes.

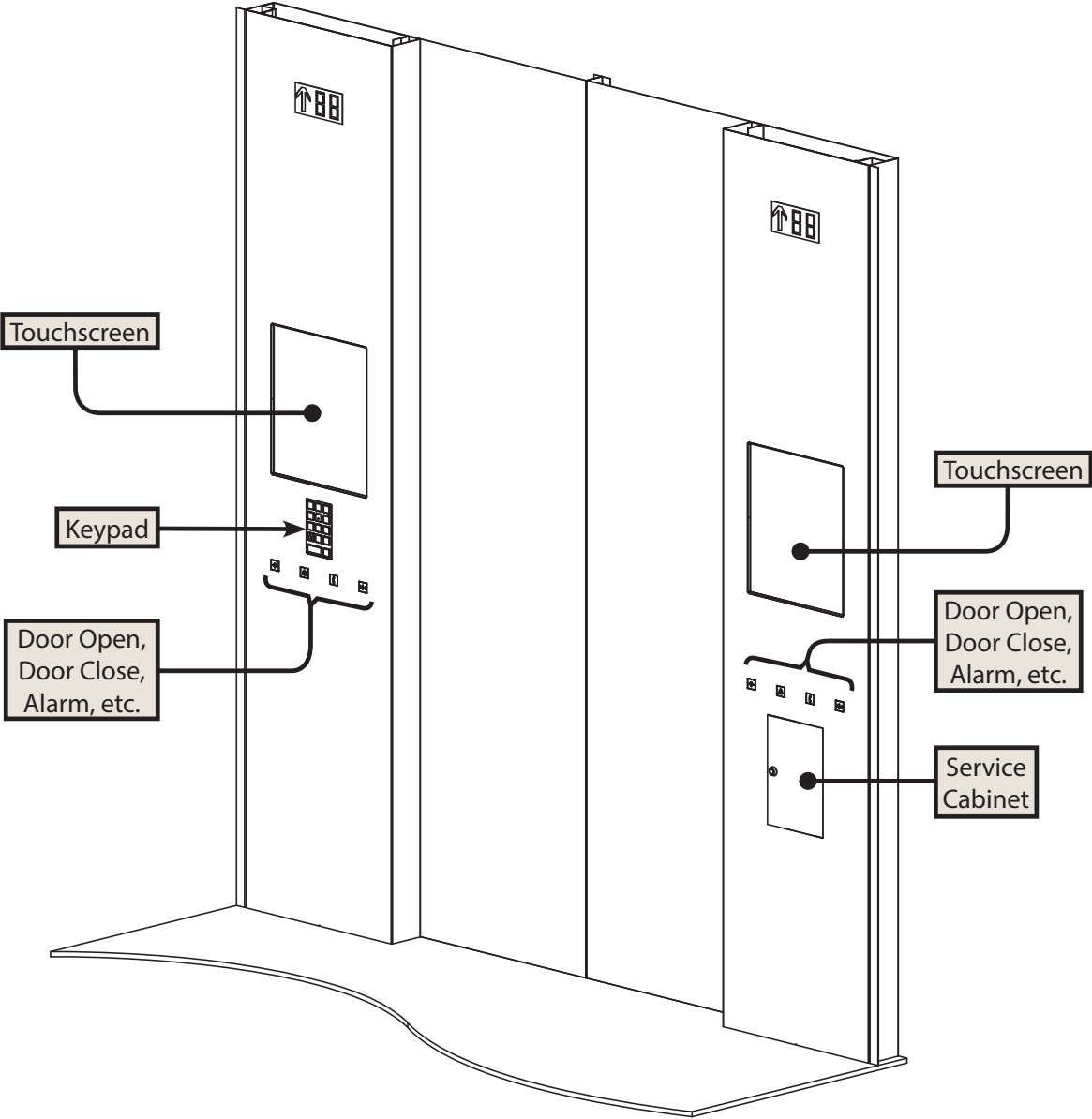

**continue to next page →**

→ continued

The following diagram shows the panels open, so that the components inside can be identified. In this diagram, only components provided by Touch-To-Go are indicated.

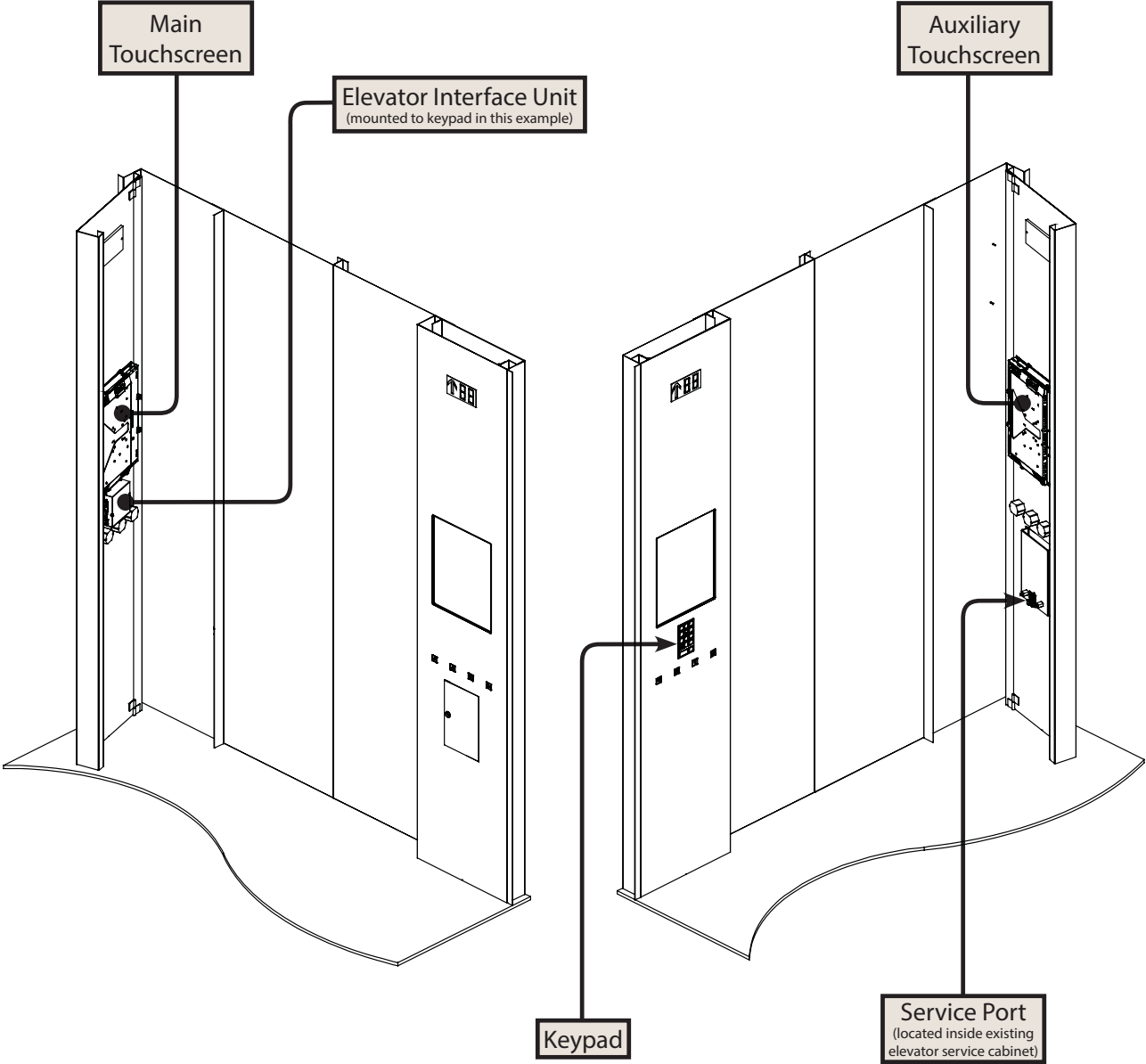

---

## Component Summary

Below is a brief summary of each component and its function in the system. A chapter in this document is dedicated to each of these items and their placement within the elevator. For details on each component, please refer to the relevant chapter.

---

### Touchscreen

The touchscreen is the primary method by which elevator passengers place floor calls in the elevator. It is a colour liquid crystal display (LCD) with an integrated touch-sensitive, impact-resistant glass panel and a watertight bezel.

In elevators with a single car-operating panel, a single touchscreen is used. In elevators with dual car-operating panels, two touchscreens are used; one in each panel.

The main touchscreen contains a CPU board that controls operation of the touchscreen system. System power is connected at the main touchscreen, and all other components of the system are wired to the main touchscreen. **One 12V power supply is required per elevator to power the system.**

An auxiliary touchscreen (if present) contains a display and touch panel only. Main and auxiliary touchscreens are the same size and mount to the same mounting stud pattern.

---

### Keypad

The keypad is a secondary method by which passengers can place floor calls in the elevator. It is intended for use by persons who are unable to use the touchscreen system (e.g. due to visual impairment or other disabilities).

The keypad complies with the 2010 ADA Standards for Accessible Design and ASME A17.1-2007 / CSA B44-07 Appendix E requirements for persons with physical disabilities. The keypad is also compliant with earlier codes CSA B44-00 and CSA B44-04.

Even if an elevator has two car-operating panels, only one keypad is installed per elevator. In elevators that service 8 or fewer floors, one to two rows of conventional elevator buttons are typically used in place of a keypad.

---

### Elevator Interface Unit

The elevator interface unit handles all communications between the elevator touchscreen system and the elevator. It is fully electrically isolated from the elevator wiring. Floor requests are sent to the elevator via contact closures, and acknowledgements are received via illumination of LEDs, similar to conventional buttons. A CAN-bus interface unit is also available for direct connection to the elevator controller.

All connections to the elevator button/indicator wiring are made at the elevator interface unit.

---

### Service Port

The service port is located in the elevator service cabinet. Along with two customer-supplied keyed switches, the service port allows for administration of the system without the need to open the elevator panels.

---

## Supported Panel Types

An elevator touchscreen system can be installed in elevators constructed using swing-return panels or applied panels.

The images below illustrate two possible panel designs for an elevator equipped with a single car-operating panel. An applied panel is shown for a four-storey building, and a swing return panel is shown for a 36-storey building. Note the use of conventional buttons instead of a keypad for the smaller building.

When considering panels of equal width, a swing return panel can often accommodate a larger screen than an applied panel due to differences in panel construction.

Panels can be solid material, or laminated (e.g. 18ga stainless veneer over 16ga steel backing plate) with a maximum overall thickness of 0.1406" (10ga stainless)

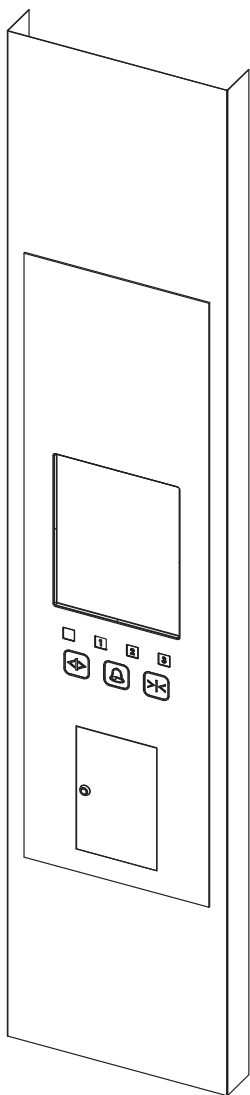

Applied Panel, 17" Touchscreen

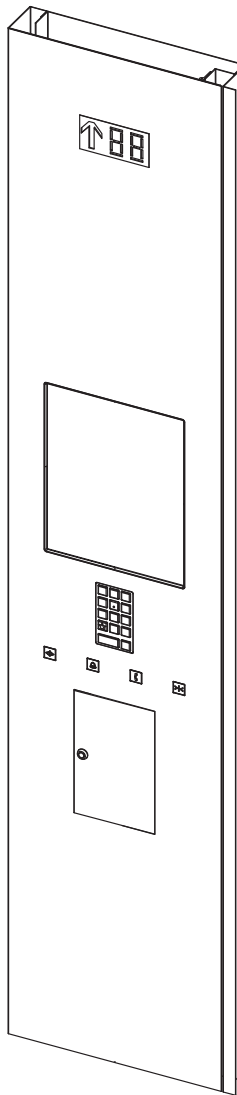

Swing Return Panel, 19" Touchscreen

## Component Placement Guidelines

The location of elevator emergency controls is often dictated by building codes. This establishes the lowest point at which these items can be placed. Place the door open, door close button and emergency controls together in a row at the lowest point allowable.

Working up from this point, add the keypad or floor buttons (as required, depending on building size and applicable codes/regulations for use of the elevator by persons with disabilities). Place these items as close as is practical to the emergency controls.

Finally, add the touchscreen display. Again, place this item as close as is practical to the keypad or floor buttons. Components should be spaced in an aesthetically pleasing manner while avoiding unnecessary vertical spacing between components to ensure that the touchscreen is kept as low as possible.

In elevators with dual car-operating panels, keypads or floor buttons are only required on one of the two panels. It is recommended that both touchscreens be mounted at the same height.

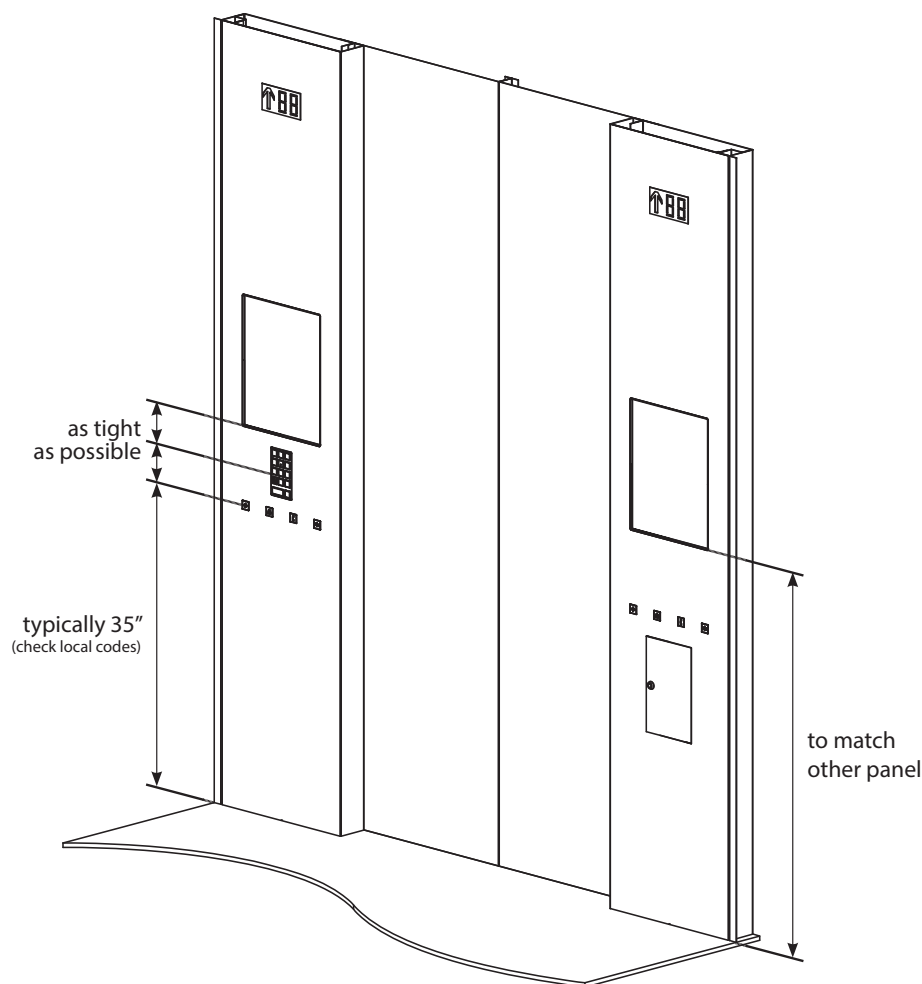

# Chapter 2: Touch Screens

## Available Sizes & Models Dimensions & Mounting on solid panel on laminated panel

### Available Sizes & Models

The following diagram shows the sizes of the standard touchscreen display. Additional non-standard sizes may be available upon special request - please contact us for more information.

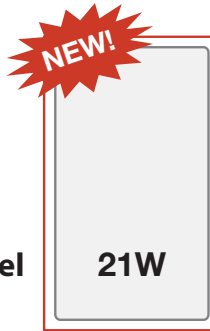

Viewable Area (in)	10.6w x 18.8h
Viewable Area (mm)	270w x 478h
General Dimensions (in) not incl. brackets	12.1w x 20.2h x 2.2d
General Dimensions (mm) not incl. brackets	308w x 513h x 56d
Resolution (px)	1080w x 1920h
Glass Type	Tempered 3mm
Viewing Angle	Wide (178°)
Panel Type	Long Life Panel (LED)



# Dimensions & Mounting

The following diagram shows the rear and side views of a typical touchscreen display with mounting hardware. Measurements are specified in millimeters.

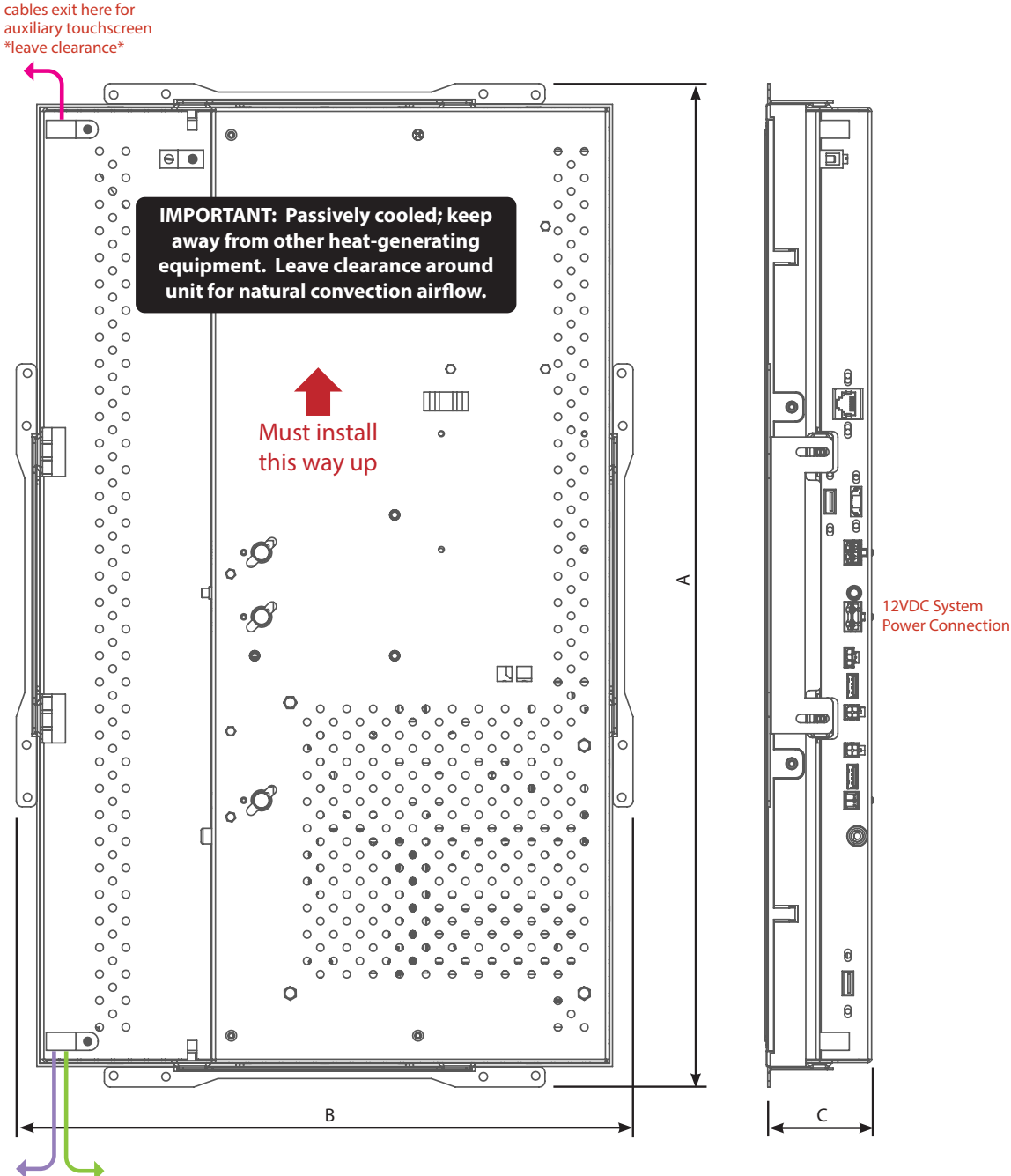

Dimension (mm)	21W Main Touchscreen	21W Aux Touchscreen
A	534.6	534.6
B	330.3	330.3
C	56.2	43.0

## Touchscreen on Solid Panel

The following diagram shows the cutout and stud locations required to mount a touchscreen display to a solid steel panel. The back side of the panel is shown.

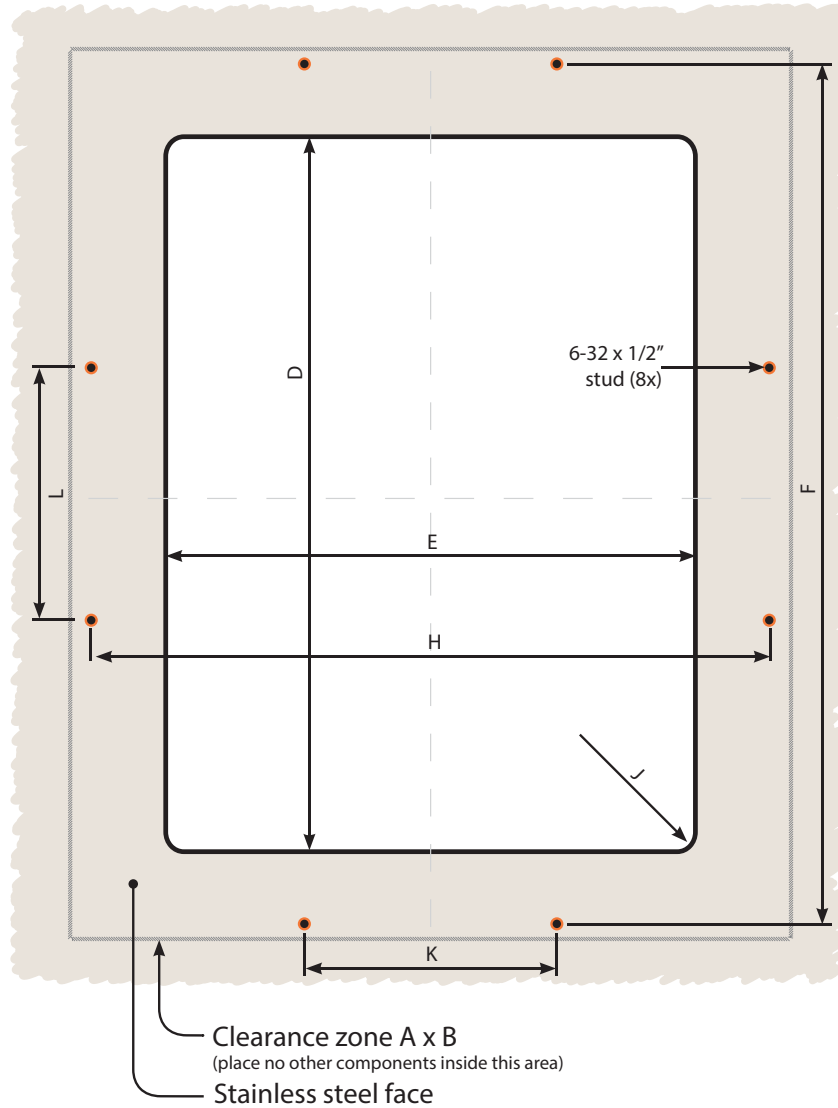

Dimension (mm)	21W Touchscreen (all models)
D (+1/-0)	486.5
E (+1/-0)	278.0
F	522.6
H	318.3
J	r2.75
K	226.0
L	226.0
A	534.6
B	330.3

## Touchscreen on Laminated Panel

The following diagram shows the cutout and stud locations required to mount a touchscreen display on a laminated panel (e.g. 18ga stainless backed with 16ga steel; other metal gauges may be used). The rear view of the panel is shown. When a laminated panel is used, the cutout in the backing plate must be larger than the cutout in the front face, as shown in the drawing below. Otherwise, the backing plate will be visible and/or there will be a gap between the touchscreen and the face of the panel.

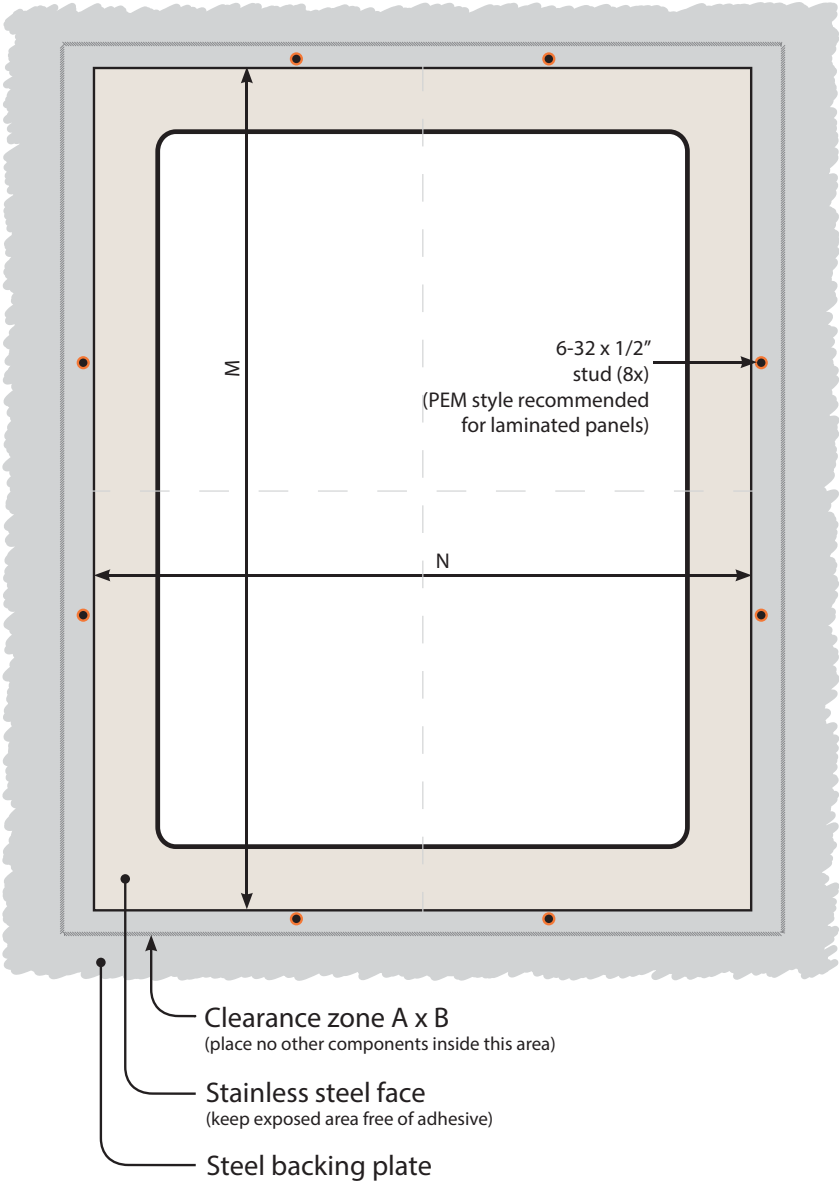

Dimension (mm)	21W Touchscreen (all models)
M (+1/-0)	513.6
N (+1/-0)	309.3

# Chapter 3: Keypad

## Overview Placement & Mounting

### Overview

The keypad is a secondary method by which passengers can place floor calls in the elevator. It is intended for use by persons who are unable to use the touchscreen system (e.g. due to visual impairment or other disabilities). It can also be used in the event that the touchscreen(s) are out of order.

Even if an elevator has two car-operating panels, only one keypad is installed per elevator. In elevators that service 8 or fewer floors, one to two rows of conventional elevator buttons are used in place of a keypad.

The keypad must be located in close proximity to the elevator interface unit. It is recommended to mount the elevator interface unit directly to the back of the keypad; mounting holes are provided in the keypad frame for this purpose.

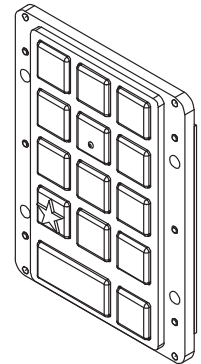

### Placement & Mounting

The keypad is usually positioned between the emergency buttons and the touchscreen. The following diagram indicates the placement of the keypad relative to these components.

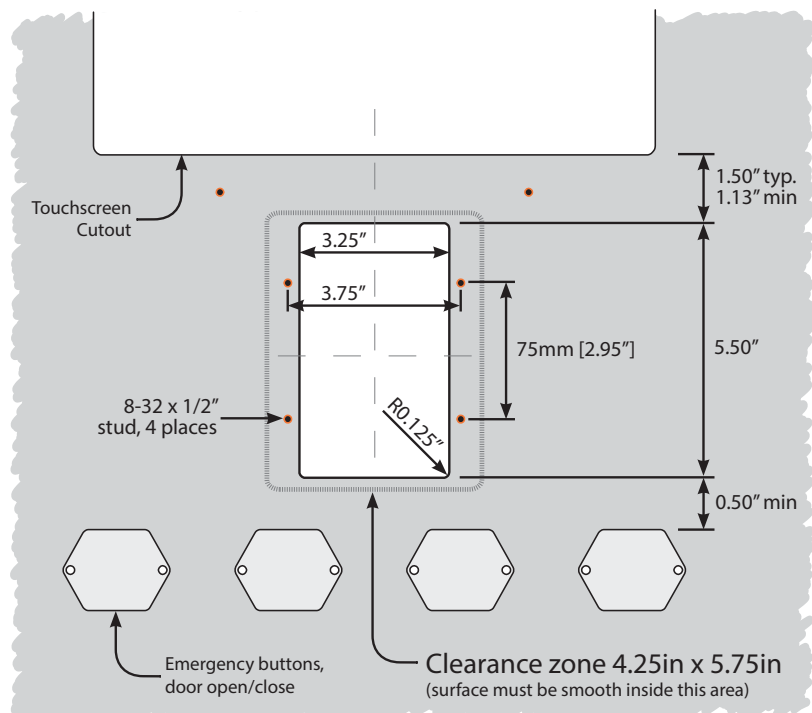

# Chapter 4: Elevator Interface Unit

## Overview

Mounting to Keypad

Mounting to Touchscreen

Mounting independently

## Overview

The elevator interface unit is the device responsible for handling all communications between the elevator and the touchscreen system.

It is available with discrete wiring (1 or 2 lines per floor) or CAN bus connection options.

The elevator button wiring connects to this device; all wires for floor buttons must be routed here. Cables from the elevator interface unit also connect to the main touchscreen. Sufficient clearance must be left around this device to allow for these connections.

## Mounting to Keypad

If a keypad is present, the elevator interface unit should be mounted to the back of the keypad. When mounted, the keypad and elevator interface unit connect directly to each other through integrated electrical connectors.

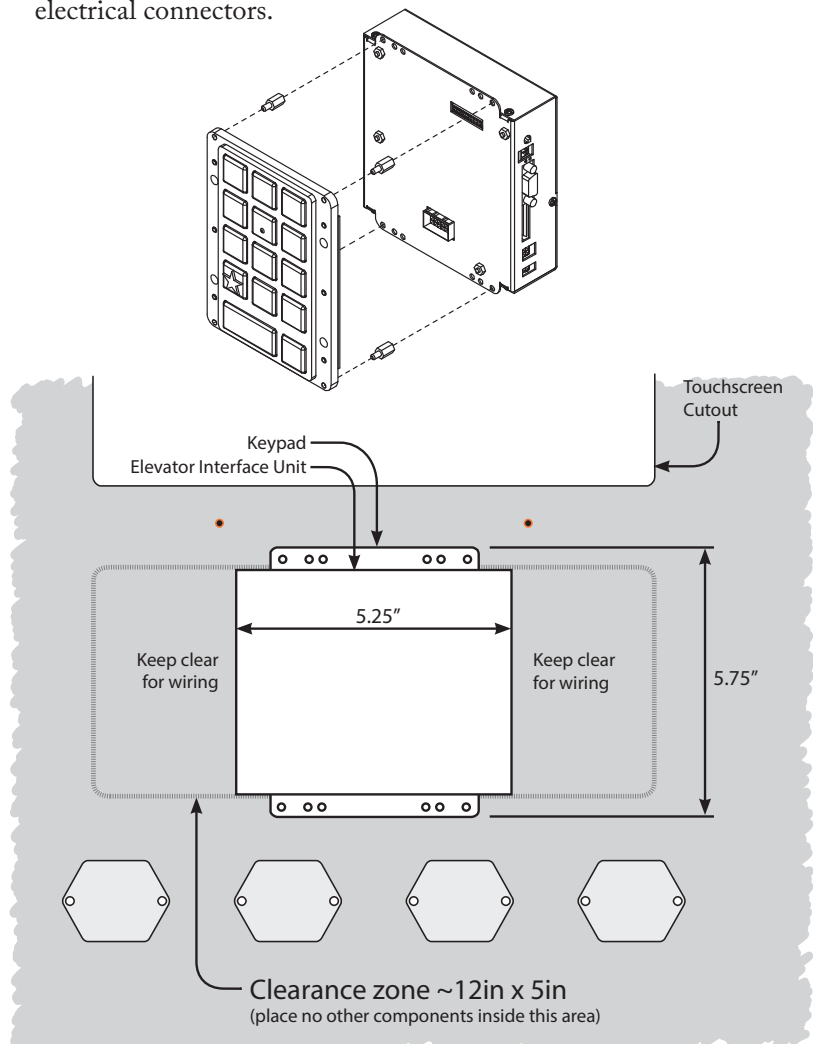

---

## Mounting to Touchscreen

If no keypad is present, the elevator interface unit can be mounted to the back of the touchscreen display. This provides significant space savings inside the elevator panel. Two M4 x 6mm screws are required.

Because the elevator interface unit is mounted directly to the touchscreen, no additional studs or other mounting hardware need to be included in the panel. The overall thickness of the 21W main touchscreen and elevator interface unit together is 3.8 inches, so please ensure adequate space is available in your COP.

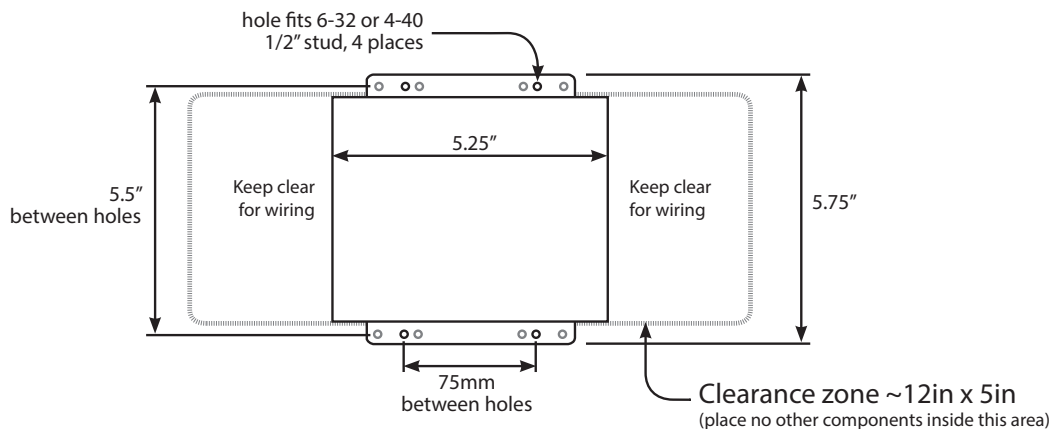
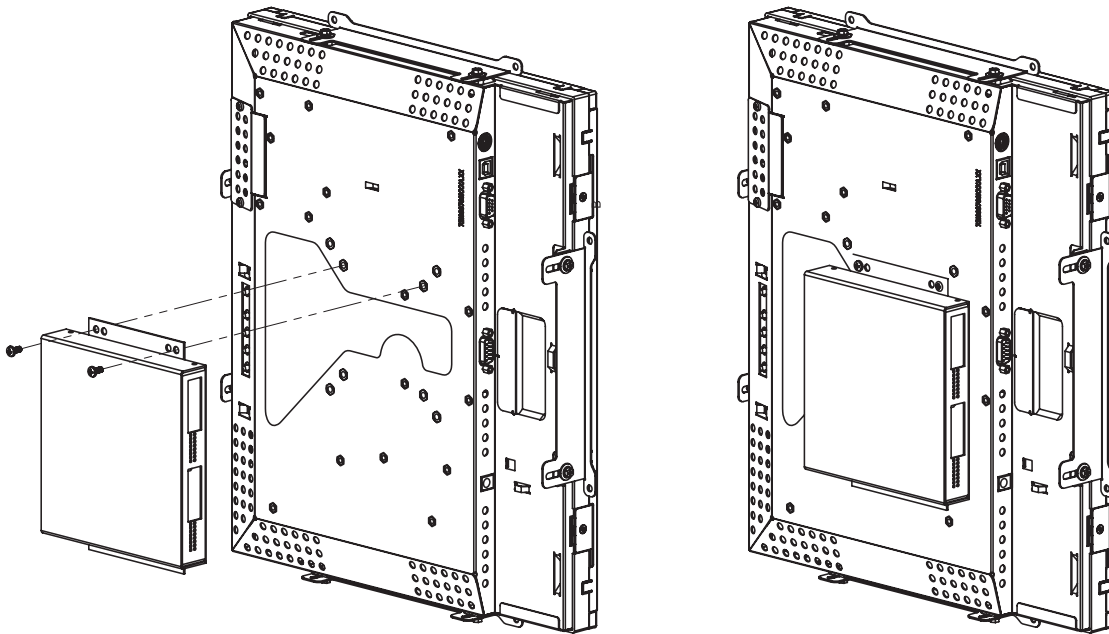

# Chapter 5: Power and Cables

## Power Cable Lengths Dimensions Connections

---

### Power

A reliable uninterrupted source of power is required to keep the system operational. System power should be provided by an AC power source of 100-120V AC 3.5A MAX, 50-60Hz or 200-240V AC 2A MAX, 50-60Hz. It must be connected to a maximum 20A branch circuit. Conductors shall be Cu, Al, or Cu-Al, and the ground wire must be 14AWG.

This AC power source connects to a 12V DC supply that is provided with the system (one per elevator) and is to be mounted in the COP. Terminal block screws are provided at the connection points.

The 12VDC power source must be wired to the main touchscreen. Connection is made to a removable terminal block plug on the rear of the main touchscreen. Low voltage DC power for all other components of the system is distributed from the main touchscreen via cables included with the system.

Electrical codes generally require a dedicated circuit for car lighting; therefore it is advised that the touchscreen system be supplied by an alternate circuit. The circuit powering the touchscreen system must shut off when the main power to the elevator control is shut off.

A protective earth grounding point is provided on the rear of the main touchscreen. This must be connected.

---

### Cable Lengths

Cables are provided with standard lengths. These cable lengths assume the following arrangement of equipment:

<b>Service Cabinet</b>	5' cable, below main touchscreen
<b>Elevator Interface Unit (and keypad if present)</b>	5' cable, below main touchscreen
<b>Auxiliary Touchscreen</b>	21' cable, routed above elevator doors to auxiliary COP
<b>Power Supply</b>	Above main touchscreen (preferred) or <b><i>at least</i></b> <u>24"</u> below main touchscreen.

The main touchscreen generates heat while operating and should not be placed near other heat-producing components such as power supplies. Sufficient clearance should be provided for airflow around the touchscreens and the 12V power supply.

# Power Supply Dimensions

The power supply dimensions are as shown below. When selecting a mounting location, please leave clearance for air flow on all sides. Also, do not place adjacent to other heat-generating components.

For optimal performance, it should be mounted in the orientation marked on its label.

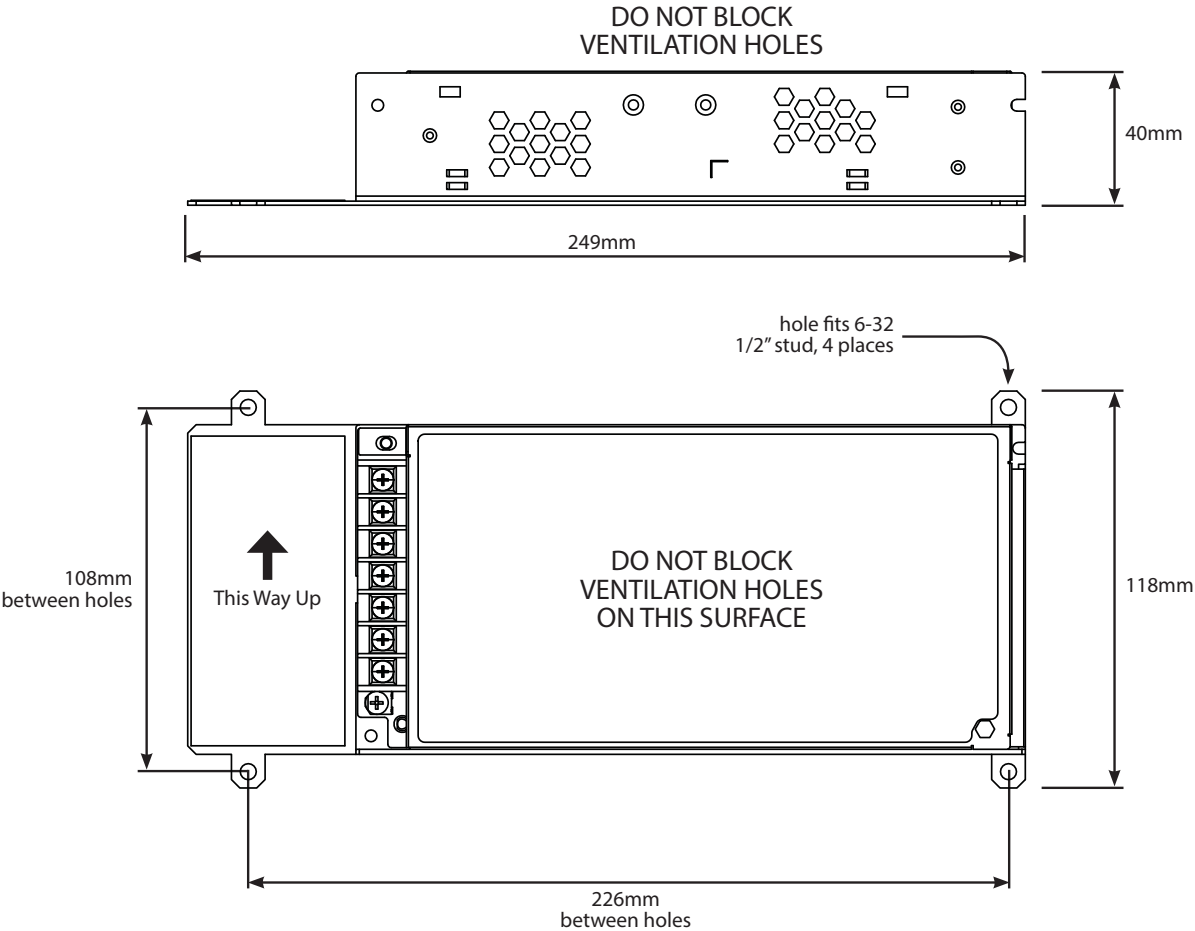



---

## Power Supply Connections

Connections must be made at the power supply for AC power input, and for 12V DC power output to the main touchscreen.

Terminals are marked on the power supply. Note that the ground conductor on the AC input must be 14AWG, and the wires should be Cu, Al, or CuAl conductors.

If your power supply is equipped with a voltage selector, you **MUST** set this **before connecting power**. If the switch is set incorrectly, the power supply and connected equipment may be damaged.

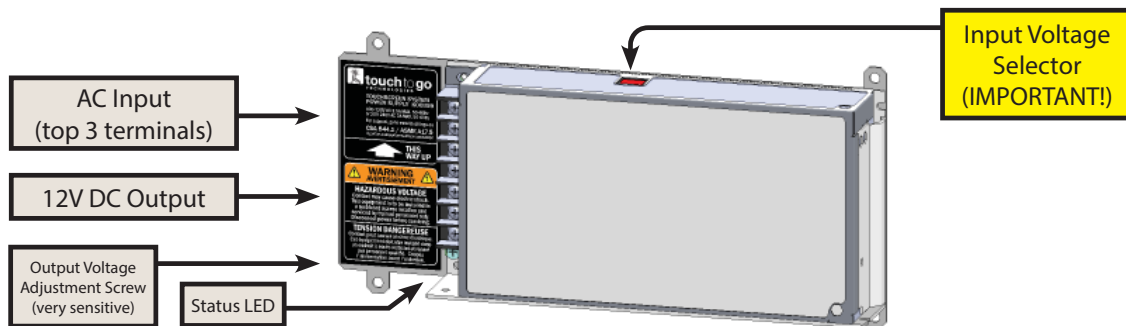

The power supply contains a voltage adjustment screw. It is very sensitive and should be turned no more than a few degrees at a time. The power supply is set from the factory to output between 12.00 and 12.75V DC.

A status LED indicates when power is available at the DC output terminals.

In the event of a short circuit on its output or an incorrect input voltage, the power supply will shut down and the LED will turn off (even if AC power is still present). If this happens, it may be necessary to disconnect AC power and wait for the internal thermal fuses to reset before the power supply will resume operation.

# Chapter 6: Service Cabinet

## Overview Placement Guidelines

### Overview

Inside the elevator service cabinet, two keyed switches and an electrical connector must be mounted. These items are required in order to configure and calibrate the touch screen system and reset the system in the event of a malfunction.

The keyed switches are customer-supplied items. The electrical connector for the service port is supplied by Touch-To-Go.

### Placement Guidelines

The following diagrams show the portion of the service cabinet subplate that is dedicated to the touchscreen system.

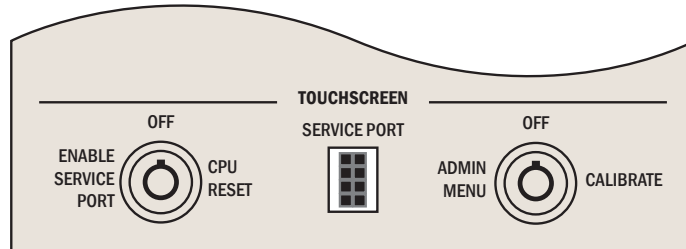

**Customer-supplied**  
3 position keyed switch  
Two independent sets of N.O. contacts  
Key removable in OFF position only  
Key trapped in other positions  
Spring-loaded in CPU RESET position only

**Suggested parts:**  
Telemecanique ZB4BG814 switch,  
ZB4BG4 collar, and two ZBE1016 contacts

**Customer-supplied**  
3 position keyed switch  
Two independent sets of N.O. contacts  
Key removable in OFF position only  
Key trapped in other positions  
Spring-loaded in ADMIN MENU position  
Spring-loaded in CALIBRATE position

**Suggested parts:**  
Telemecanique ZB4BG714 switch,  
ZB4BG4 collar, and two ZBE1016 contacts

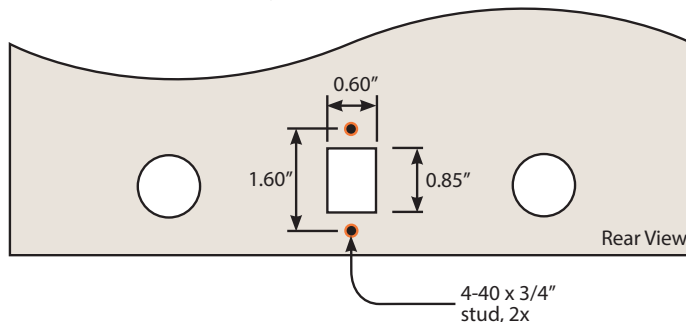
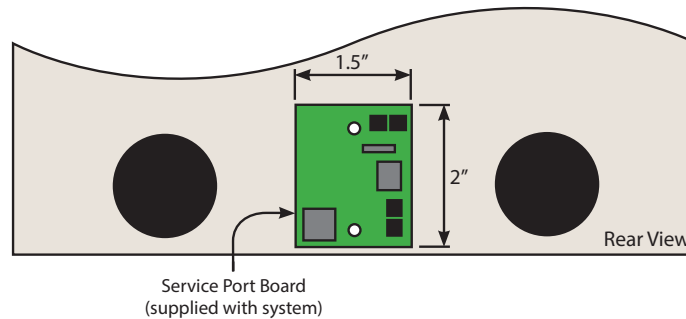

# Chapter 7: Power Saving Mode

- Overview
- External Signals
- Passenger Sensor
- Connecting External Signals Using a Passenger Sensor
- Sensor Placement
- Sensor Mounting
- The Wrong Way

---

## Overview

Touch-To-Go Elevator Touchscreen Systems include a power-saving mode which can turn off the touchscreens after a configurable period of inactivity. Enabling this feature will prolong the life of the touchscreens in addition to conserving energy.

This mode can be configured on a fixed schedule (for elevators that are known to be unused at certain times of day) or it can be configured to operate automatically.

For automatic operation, the system requires a means of detecting when passengers are present in the elevator so that the power to the touchscreens can be restored.

Once the system is alerted to passenger presence, the LCD screens resume operation within approximately 1 second. Touching the screens or pressing a key on the keypad will also return the system to normal operation.

There are several methods by which the system can be notified of passenger presence. The exact method you choose will depend on the signals available in your elevator.

---

## External Signals (recommended)

An external signal can be provided to the touchscreen system to notify it of passenger presence. The system may be used with almost any electrical signal that indicates that passengers are in the elevator, such as:

- A specific signal from the elevator controller indicating elevator occupancy
- Power to existing car lighting which is turned on/off by the elevator controller based on occupancy (**recommended**)
- Door operator signals or limit switches which are triggered upon opening the elevator doors
- Door safety edges (IR) which are triggered when passengers walk through

---

## Passenger Sensor

If no external signals are available, a Touch-To-Go passenger sensor module is available. It detects the motion of passengers in the elevator, and must be mounted in the ceiling of the elevator where it is exposed to the elevator cab. It cannot be behind a protective cover, as this blocks the detection mechanism.

## Connecting External Signals

**Do not connect external signals directly to the touchscreen system or damage will occur.** These external signals must be connected to the touchscreen system through a relay to provide electrical isolation. The relay coil should be powered by the device being used to indicate elevator occupancy (the car lighting, door operator, etc.). The relay should have a pair of normally-open, low-current, low-voltage, low-resistance contacts that close to indicate passenger presence. Contact closure can be momentary or constant.

Connections are made to the touchscreen system's service port board, which is mounted behind the elevator's service cabinet. A 3-pin JST connector and terminal block connection are provided; either may be used.

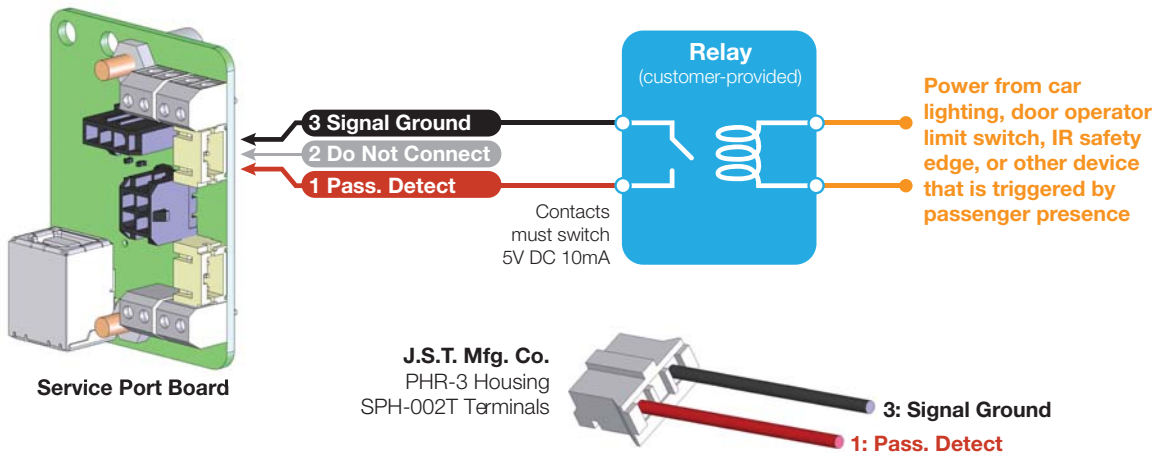

## Using a Passenger Sensor (by special order only)

If no external signals are available to indicate passenger presence, a passenger sensor may be used. Sensors are approximately 0.5 inches in diameter and are available in black or white. The sensor board is 1.5" square.

Sensors should be placed to optimize detection range while also being located in a position where they are unlikely to be blocked or damaged. Each sensor can detect passengers in a 100° area extending about 7 feet from the sensor:

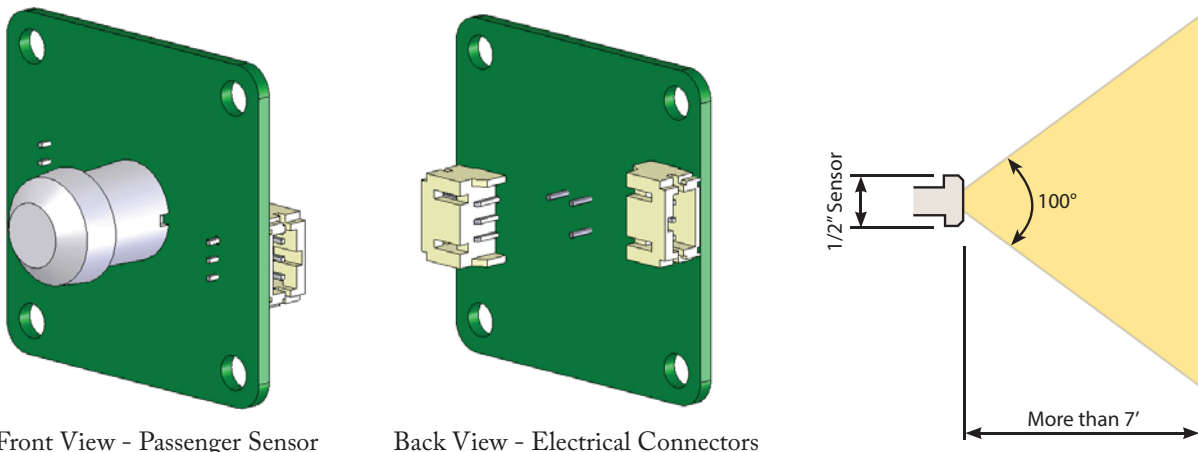

---

## Sensor Placement

The ideal location for the sensor is in the ceiling of the elevator cab. From this location, a single sensor can face downwards and detect passengers as they enter the elevator. A sensor in this location is also inconspicuous and unlikely to get damaged. The header above the door is another ideal location, detecting passengers as they enter or exit the elevator.

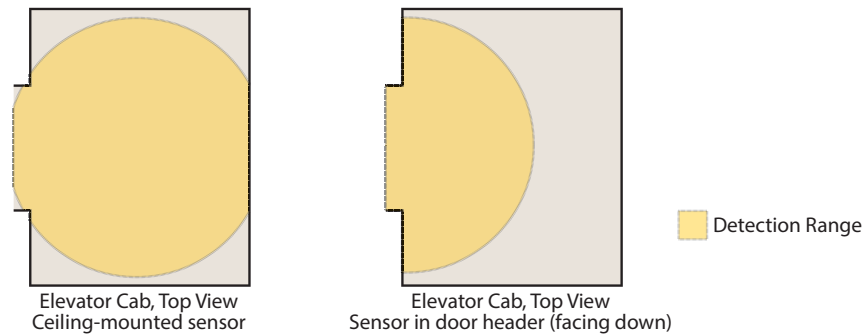

An alternate option is to place sensor(s) above the touchscreens at the top of each car-operating panel. This simplifies installation (as all wiring can be contained within the panel) but makes the sensors more conspicuous and more susceptible to damage, with a slightly more limited detection range.

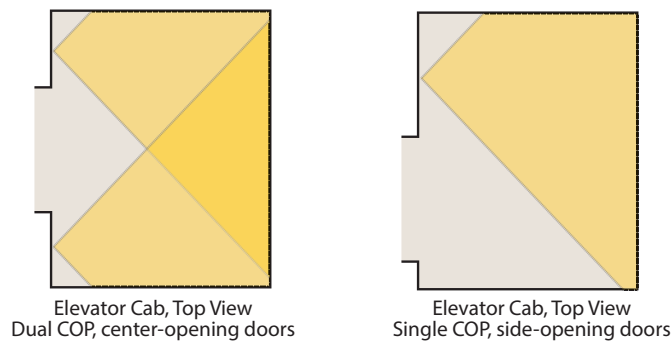

The first sensor in each elevator must be wired to the service port board in the elevator's service cabinet. Additional sensors can be wired to each other (in a chain) or to the service port board.

---

## Sensor Mounting

A 1/2" hole exposes the sensor to the elevator cab. Sensors mount on a set of four 4-40 studs spaced in a 1.2" square pattern. An optional mounting bracket (P/N M00052) is also available which contains these studs.

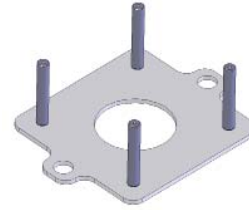
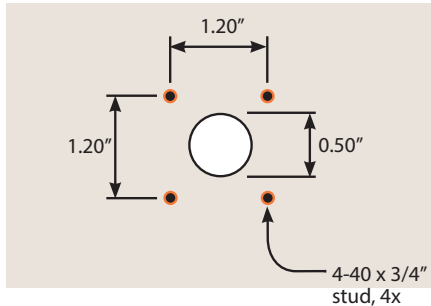

Optional mounting bracket  
Part number M00052  
(holes spaced 1.81")

---

## The Wrong Way

Do not power the touchscreen systems from a power source that switches off when the elevator is idle. If you do this, the systems will take approximately 45 seconds to restart when the power is restored, which may result in passengers needing to wait for the system to become operational before they can use the touchscreens. For example, powering the system from the car lighting circuit may cause problems if the lighting is switched off automatically to save power.

For proper operation, the systems must be constantly powered, and then an external signal may be used to control power-saving mode.

# Chapter 8: Position Indicator

## Overview Requirements

### Overview

The system provides the option to interface with a 4-wire serial position indicator bus from DMG S.p.A. This provides the touchscreen system with information about the elevator's current position and direction of travel.

DMG position encoder models DEUM.E08 and DEUM.M16 are supported.

### Requirements

To include the optional DMG Position Indicator Interface (Touch-To-Go part number M00049), please allocate space for the decoder module in the car operating panel. It comes with a 16" cable and connects to the elevator interface unit. Therefore, it should be placed in close proximity to the elevator interface unit.

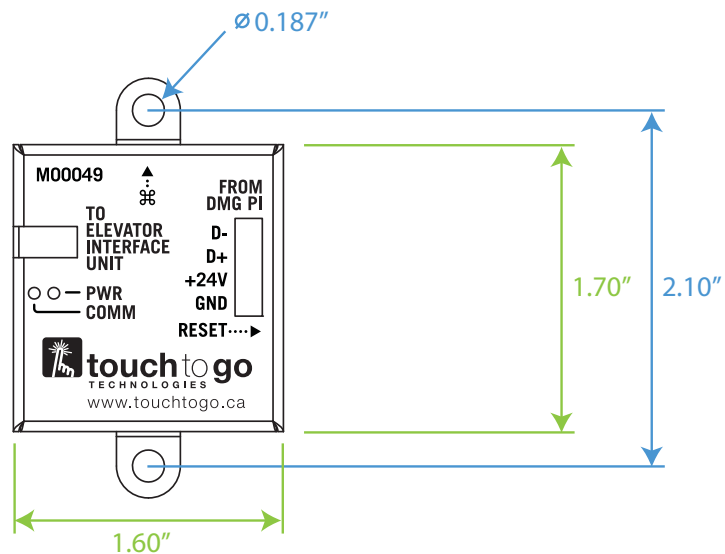

We also offer an alternate configuration of the DMG Position Indicator Interface (Touch-To-Go part number K00599), that connects directly to the main touchscreen's accessory USB port. This can simplify wiring and placement, as it does not need a mounting location allocated in the COP.

# Chapter 9: Other Items

## Network Requirements Elevator Button Wiring Conduit / Duct

---

### Network Requirements (optional)

Multiple elevators can be networked together to simplify processes such as system configuration or graphics updates.

If systems are to be networked, a piece of twisted pair cable must be included in the traveling cable. Cables from all elevators must terminate at a common point in the machine room.

Inside the elevator, the twisted-pair cable must terminate near the main touchscreen. Space must be allocated for installation of a network device and its power supply.

---

### Elevator Button Wiring

These connections are particular to each elevator, so they cannot be specified in this document. A separate electrical schematic is provided showing the electrical connections for each elevator.

All button wiring terminates at the elevator interface unit, so sufficient wire should be pulled to reach the location of this device. Conventional elevator buttons can be wired in parallel with the elevator interface unit as necessary.

---

### Conduit / Duct

For elevators with dual car-operating panels, a conduit or duct with a diameter of *at least 2"* must link the two panels. This is usually run above the elevator door; cables are approximately 21' long.

It is necessary to route a bundle of cables between the panels at the time of installation. The cables can be damaged by sharp bending and have non-removable plugs on each end. If the conduit/duct is undersized, installation will be more difficult.



# Chapter 10: Checklist

## Panel Design Checklist

### Panel Design Checklist

This checklist helps ensure that all of the required features have been included in your elevator car-operating panel designs. Please contact your Touch-To-Go project manager to arrange a final drawing review prior to panel fabrication. This review service is included with your system purchase at no additional charge.

#### Touchscreens

- 8 studs are present and correctly located for each touchscreen?
- Drawings for the correct touchscreen size have been used?
- Corners of touchscreen cutout have the correct radius?
- For laminated panels, backing plate cutout size is correct?

#### General

- Traditional elevator buttons have been included for emergency functions as well as door-open and door-close?
- The panel has adequate depth and width to accommodate the components?
- Components are spaced appropriately and in an aesthetically pleasing manner?
- Car-operating panel hinges are strong enough to support the weight of the touchscreens and other components?
- In elevators with dual car-operating panels, conduit or duct is present linking the two panels?
- If networking is required, a twisted-pair cable has been allocated in the traveling cables?
- An unswitched source of AC power is available at the main touchscreen, supplied by a separate circuit from car lighting?
- A relay has been provided to indicate passenger presence / elevator occupancy (e.g. from car lighting, door operator, etc.)?
- Code compliance has been verified?

#### Service Cabinet

- Service cabinet has the required keyed switches?
- Keyed switches are labeled & positioned appropriately?
- Service cabinet has cutout and studs for service port?

#### Keypad

- Cutout size and stud locations are correct?
- Correct clearance has been left between adjacent components?
- Any special button requirements (other than 0-9, P, \*) have been discussed with your Touch-To-Go project manager?

#### Elevator Interface Unit

- Mounting location has been selected (keypad / touchscreen / other; must be mounted to keypad if keypad is present)
- Space for wire & cable routing has been allocated?



A MEMBER OF THE DMG  
GROUP OF COMPANIES

[www.dmg.it](http://www.dmg.it)



**touch to go**  
TECHNOLOGIES

ELEVATOR TOUCHSCREEN SYSTEMS

Box 61070, KENSINGTON RPO  
CALGARY, ALBERTA  
CANADA T2N 4S6  
(403)775-5177

email: [info@touchtogo.ca](mailto:info@touchtogo.ca)  
web: [www.touchtogo.ca](http://www.touchtogo.ca)

CONTACT OUR EXCLUSIVE VALUE-ADDED RESELLER:



**Elevator Fixtures**

115 CITY VIEW DR.  
ETOBICOKE, ONTARIO  
CANADA M9W 5A8  
(866) 967-8500

[customerservice@madfixtures.com](mailto:customerservice@madfixtures.com)  
[www.madfixtures.com](http://www.madfixtures.com)